



## WASHER-EXTRACTOR 8 KG, MANUAL & AUTOMATIC DOSING

Model: WH6-8

Article no: 9867630288

Power supply: 230V 1Ph ~60Hz

The WH6-8 washer-extractor has a certified ergonomic design with a human-centered approach for outstanding user experience. The Compass Pro® microprocessor offers a large display, one control knob for easy program and language selection, and quick choice and option buttons for the most frequently used wash programs. Four-compartment detergent box for flexible manual dosing of powder or liquid detergent. Professional door with gasket and sturdy hinges built for heavy-duty operation, hygiene, and long-term savings.

The washer has programs optimized for the lowest consumption of water, energy, and detergent. Automatic Savings weighs the linen and adjusts the water level to the amount of linen, saving water and energy at less than full load.

Monitoring the equipment's status and performance from anywhere allows us to take action to improve the business. Connectable to OnE Laundry, the personal assistant for hygiene validation, process management, and revenue management.

### MAIN FEATURES

- Prepared for automatic dosing (5 liquid signals) and extra I/O board
- The Line 6000 series are the first washer/dryers to receive certification in ergonomic design
- Silver grey powder-painted galvanized steel exterior
- Compass Pro® microprocessor
- 4-compartment detergent box
- Heavy-duty operation door
- High extraction force
- Automatic savings of water and energy
- Power balance
- Connectable to "OnE Laundry"

WH6-8, 9867630288

15-01-24 (17:36)

Subject to change without notice  
For correct installation, refer to the installation manual

<b>Model Number Specific</b>	WH6-8
<b>Voltage (V)</b>	230
<b>Phase</b>	1
<b>Frequency (Hz)</b>	60
<b>Loading (kW)</b>	5,7
<b>Fuse (A)</b>	25
<b>IP Class</b>	X4
<b>Capacity (kg)</b>	8
<b>Capacity, filling factor</b>	1:9
<b>Capacity, water evaporation, max (L/h)</b>	170
<b>Width, net (mm)</b>	720
<b>Depth, net (mm)</b>	721
<b>Height, net (mm)</b>	1132
<b>Weight, net (kg)</b>	158
<b>Weight, gross (kg)</b>	169
<b>Volume, net (m3)</b>	0,59
<b>Volume, gross (m3)</b>	0,76
<b>Connection Cable, length (m)</b>	0
<b>Plug type</b>	None
<b>Cold water inlet, diameter (")</b>	3/4
<b>Detergent box</b>	Top
<b>Door Hanging</b>	Right
<b>Drain pipe, diameter (mm)</b>	50
<b>Drain pump</b>	No
<b>Drum type</b>	Stainless steel
<b>Energy consumption, Normal, 60°C (kWh)</b>	1,1
<b>Exterior</b>	Colored
<b>G factor</b>	450
<b>Noise level &lt;(dB)</b>	73
<b>Prepared for dosing system</b>	Yes
<b>SS Front panel</b>	No
<b>Water pressure, max (Bar)</b>	600
<b>Water pressure, min (Bar)</b>	200

## INCLUDED IN DELIVERY

Drain hose Ø 75mm L=440mm. Water hoses are available as accessories.

Loipart AB (HQ), Sweden  
Tel. +46 313 920 100, loipart@loipart.se

LMG Finland oy, Finland  
+358 40 664 6680, lmg@lmg.fi



Loipart USA inc, USA  
Tel. +1 954 530 5276, loipartusa@loipart.com

Loipart SEA Pte Ltd, Singapore  
Tel. +65 674 99 100, contact@loipart.sg

Visit us at [www.loipart.com](http://www.loipart.com)

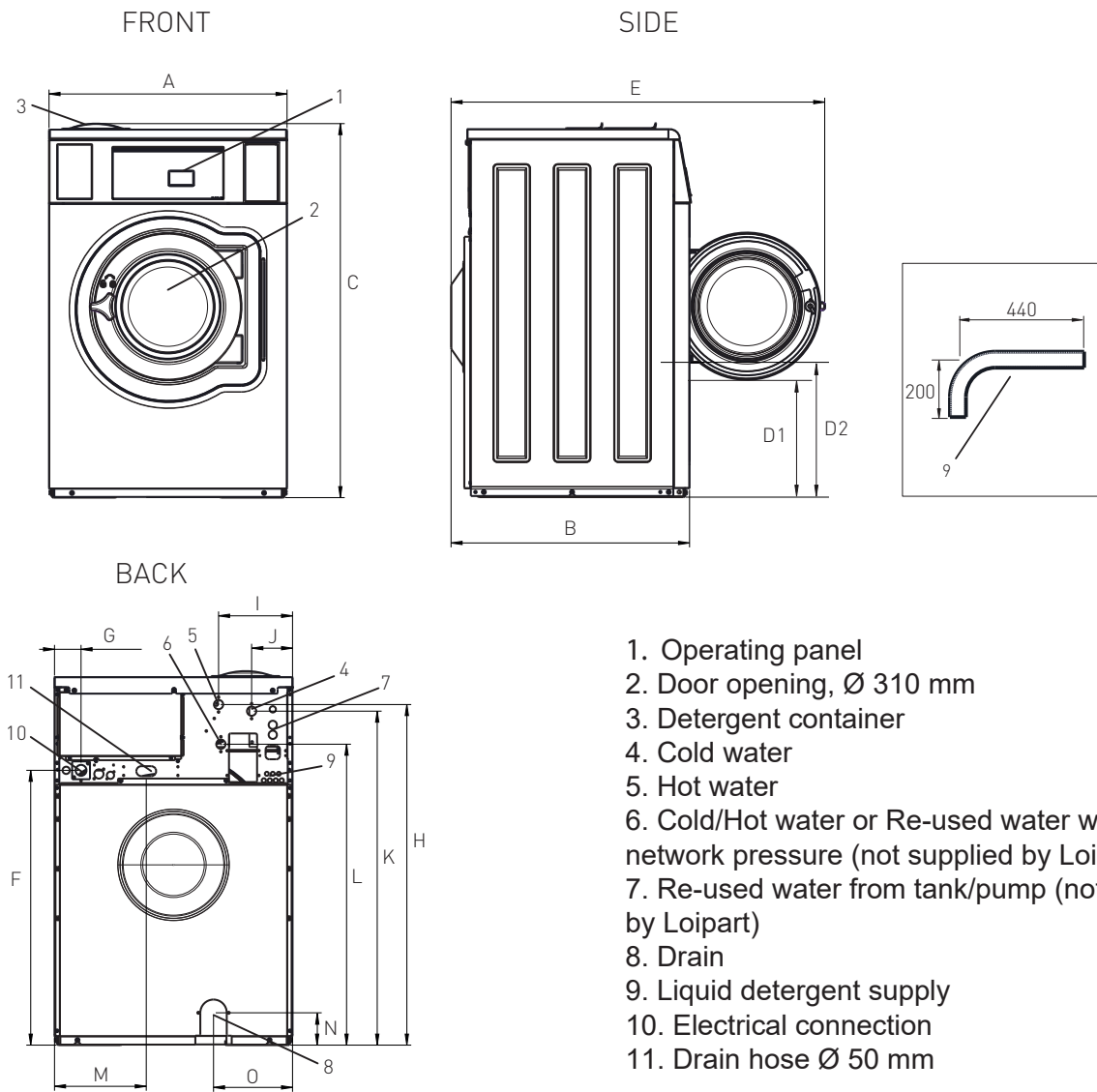

- 1. Operating panel
- 2. Door opening, Ø 310 mm
- 3. Detergent container
- 4. Cold water
- 5. Hot water
- 6. Cold/Hot water or Re-used water with network pressure (not supplied by Loipart)
- 7. Re-used water from tank/pump (not supplied by Loipart)
- 8. Drain
- 9. Liquid detergent supply
- 10. Electrical connection
- 11. Drain hose Ø 50 mm

Dimensions (mm)

A	B	C	D1	D2	E	F	G	H	I	J	K	L	M	N	O
720	720	1135*	360	425	1135	835	80	1035	215	125	1015	915	280	100	240

Install the machine close to a floor drain or open drain. The machine should be positioned so that there is plenty of room for working, both for the user and service personnel. The figure shows minimum distance to a wall and/or other machines. Failure to respect the prescribed distances will prevent easy access for maintenance and service operations.

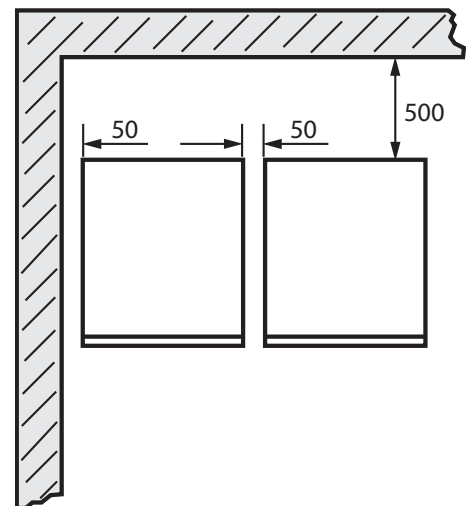

MARINE INSTALLATION

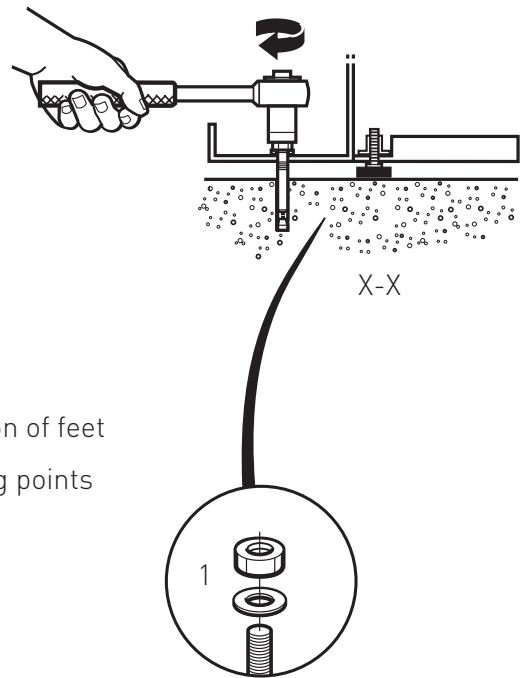
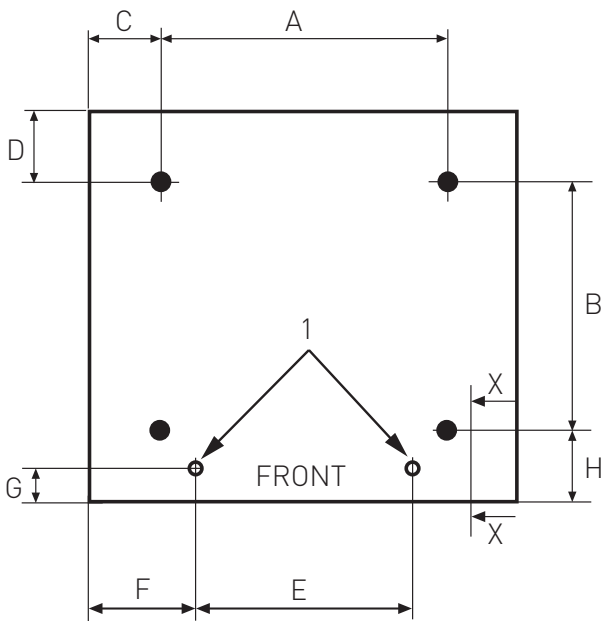

- = position of feet
- ⊙ = drilling points

(mm)

A	B	C	D	E	F	G	H
495	460	110	125	375	170	40	100

To ensure steadiness of the machine; the machine must be fastened to the floor. Place the machine over the two drilled holes. The holes are at the front of the machine. Level the machine with the feet of the machine. Screw in the feet as much as possible before starting to level the machine. This will make the machine stand steadier. The maximum height adjustment of the feet is 30 mm. Insert the expansion bolts (1) into the holes drilled in the floor. Fit the washers and nuts and tighten with tightening torque 5 Nm.

POSITION ON VESSEL

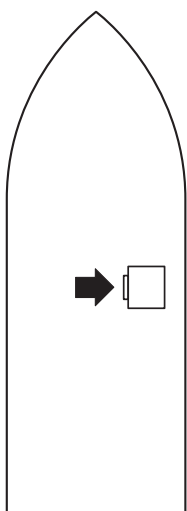

The unit shall be placed as in the figure.