



PLANETARY MIXER 60L WITH HUB

Model: BMX60AS

Article no: 600279

Power supply: 400V 3Ph ~50Hz

This professional beater mixer is designed to withstand the strong demands of bakery and pastry making. Reinforced body for heavy-duty use with 18/8 (AISI 302) 60-litre stainless steel bowl and a capacity of up to 20 kg. With a powerful asynchronous motor (1.5 kW) with 10 speeds (20-180 rpm). Solid BPA-free safety screen, covering the stainless steel wire one, limits the flour and unsafe dust particles when used in bakery and pastry preparation. The bowl detection device allows the mixer to switch on only when the bowl and the safety screen are properly installed and positioned together. Raising and lowering of the bowl controlled by lever with an automatic locking of the bowl when in the raised position. The flat touch button control panel is waterproof (IP55) and equipped with a timer from 0-59 min. Equipped with accessory drive hub type H.

MAIN FEATURES

- Made for heavy-duty use.
- Capacity of up to 20 kg (cold water paste 60% hydration).
- Suitable for 400-800 meals per service
- Pivoting and removable BPA-free wire safety screen.
- Waterproof touch button control panel.
- Bowl detection device.
- Overload protected planetary system and motor.
- Adjustable feet to perfect stability.

BMX60AS, 600279

15-01-24 (15:56)

Subject to change without notice
For correct installation, refer to the installation manual

TECHNICAL DATA

BMX60AS, 600279, 15-01-24 (15:56)

Model Number Specific	BMX60AS
Voltage (V)	400
Phase	3
Frequency (Hz)	50
Loading (kW)	1,5
IP Class	34
Capacity (L)	60
Capacity (kg)	20
Width, net (mm)	685
Depth, net (mm)	1087
Height, net (mm)	1445
Weight, net (kg)	307
Weight, gross (kg)	337
Volume, net (m3)	1,08
Volume, gross (m3)	1,4
Connection Cable, length (m)	0
Attachment drive	Yes
Installation, type	Floor model
Mixer, type	Planetary
Noise level <(dB)	70

INCLUDED IN DELIVERY

Spiral hook, wire whisk, paddle (and mixing bowl 60 L).

Loipart AB (HQ), **Sweden**
Tel. +46 313 920 100, loipart@loipart.se

LMG Finland oy, **Finland**
+358 40 664 6680, lmg@lmg.fi



Loipart USA inc, **USA**
Tel. +1 954 530 5276, loipartusa@loipart.com

Loipart SEA Pte Ltd, **Singapore**
Tel. +65 674 99 100, contact@loipart.sg

Visit us at www.loipart.com

FRONT

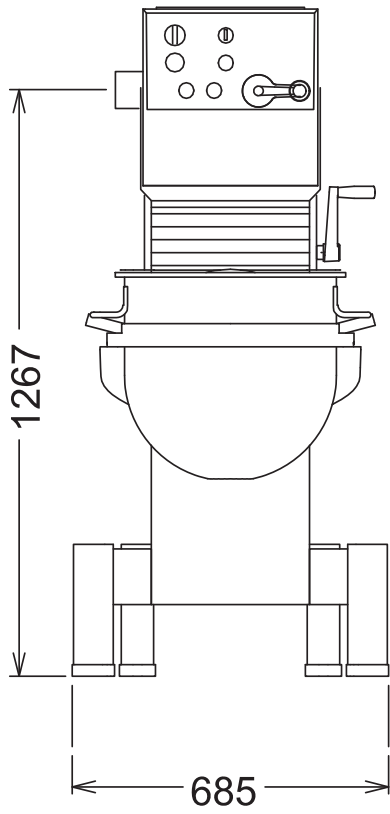

SIDE

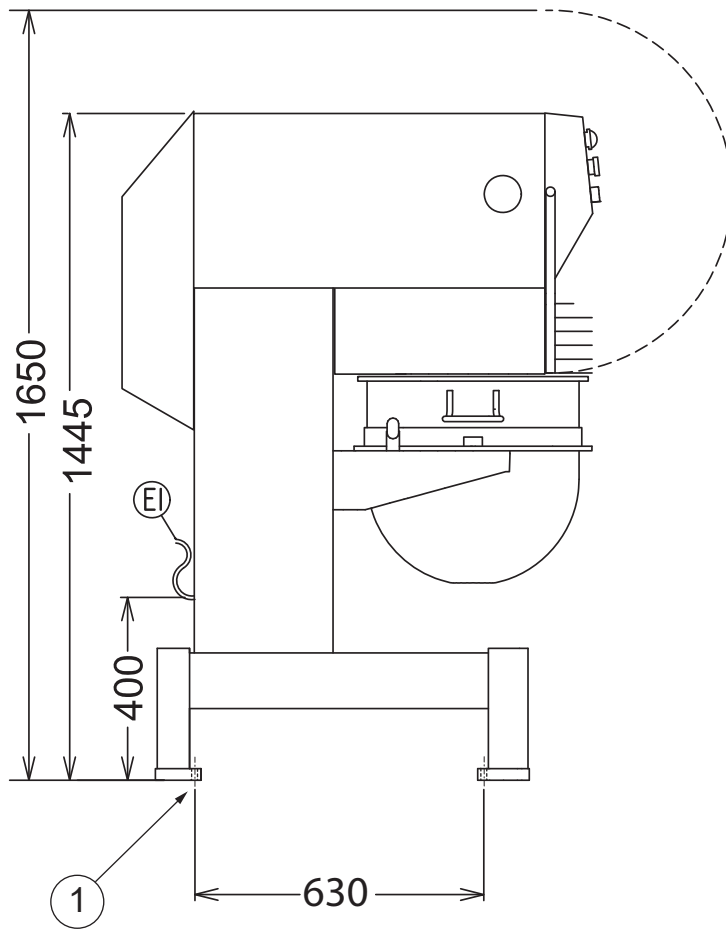

DETAIL OF FASTENING POINT

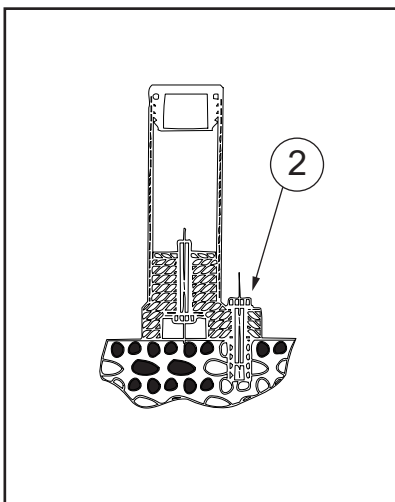

TOP

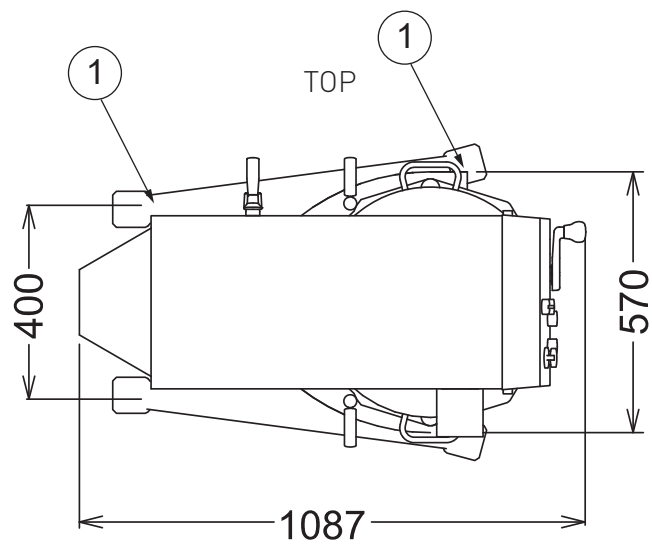

1. Anchor point
2. Counter drill the attachment holes of the feet (8 mm dia. screw max., min. length 30 mm, rawl plugs not supplied).