



## REFRIGERATED COUNTER, 3 DOORS, 1660MM

Model: CDGN-M-1-C1-1-1

Article no: L22085

Power supply: 230V 1Ph ~50/60Hz

The range of cold units includes various types of refrigerated drawers, cabinets, and worktops. Thanks to the flexible modular construction, they are easy to combine to create a customized food service system that best suits individual needs. All units are made of stainless steel and comply with the hygiene standards for professional galleys.

This refrigerated counter is intended to store cold foods for a short period. All surfaces are stainless steel and come with 63 mm adjustable marine feet. The counter has GN-sized cupboards and drawers and includes a locking latch with a key. The drawers have removable slide rails and plastic magnetic gaskets.

The technical features of products are designed to meet the requirements of cold storage in ambient temperatures up to +30°C. The refrigeration module is removable without tools and comes with automatic defrost and evaporation of defrost water. A ventilated refrigeration module ensures even temperature distribution.

The unit has 50 mm thick walls, and the insulating material is polyurethane.

### MAIN FEATURES

- Temperature adjustable between +2 and +6°C
- Digital temperature display
- CFC and HCFC-free insulation
- Unit is CE marked
- Refrigerator module 250 W
- Refrigerant type R290

CDGN-M-1-C1-1-1, L22085  
26-01-24 (11:33)

## TECHNICAL DATA

CDGN-M-1-C1-1-1, L22085, 26-01-24 (11:33)

<b>Model Number Specific</b>	CDGN-M-1-C1-1-1
<b>Voltage (V)</b>	230
<b>Phase</b>	1
<b>Frequency (Hz)</b>	50/60
<b>Loading (kW)</b>	0,25
<b>IP Class</b>	44
<b>Capacity (L)</b>	303
<b>Width, net (mm)</b>	1660
<b>Depth, net (mm)</b>	650
<b>Height, net (mm)</b>	900
<b>Weight, net (kg)</b>	150
<b>Weight, gross (kg)</b>	160
<b>Volume, net (m3)</b>	0,97
<b>Volume, gross (m3)</b>	1,26
<b>Connection Cable, length (m)</b>	3
<b>Plug type</b>	Schuko
<b>Adapted for container sizes</b>	GN
<b>Ambient temperature, max (°C)</b>	30
<b>Automatic defrost</b>	Yes
<b>Certifications</b>	CE
<b>Cooling capacity (W)</b>	250
<b>Cooling fan</b>	Yes
<b>Doors, qty (pcs)</b>	3
<b>Filling factor refrigerant (g)</b>	150
<b>Installation, type</b>	Floor model
<b>Locking device, included</b>	Yes
<b>Marine feet</b>	Yes
<b>Noise level &lt;(dB)</b>	70
<b>Pan sizes</b>	GN1/1
<b>Placing</b>	Free standing
<b>Refrigerant type</b>	R290
<b>Sections, qty (pcs)</b>	4

Loipart AB (HQ), Sweden  
Tel. +46 313 920 100, loipart@loipart.se

LMG Finland oy, Finland  
+358 40 664 6680, lmg@lmg.fi



Loipart USA inc, USA  
Tel. +1 954 530 5276, loipartusa@loipart.com

Loipart SEA Pte Ltd, Singapore  
Tel. +65 674 99 100, contact@loipart.sg

Visit us at [www.loipart.com](http://www.loipart.com)

# DIMENSIONS

Model: CDGN-M-1-C1-1-1 Rev. 1

SIDE

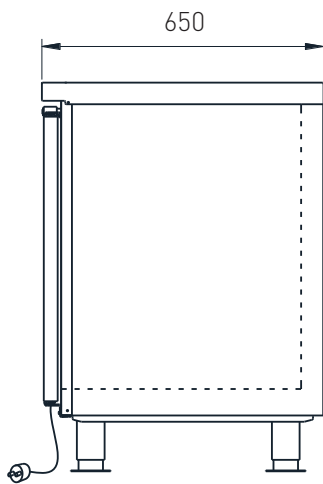

FRONT

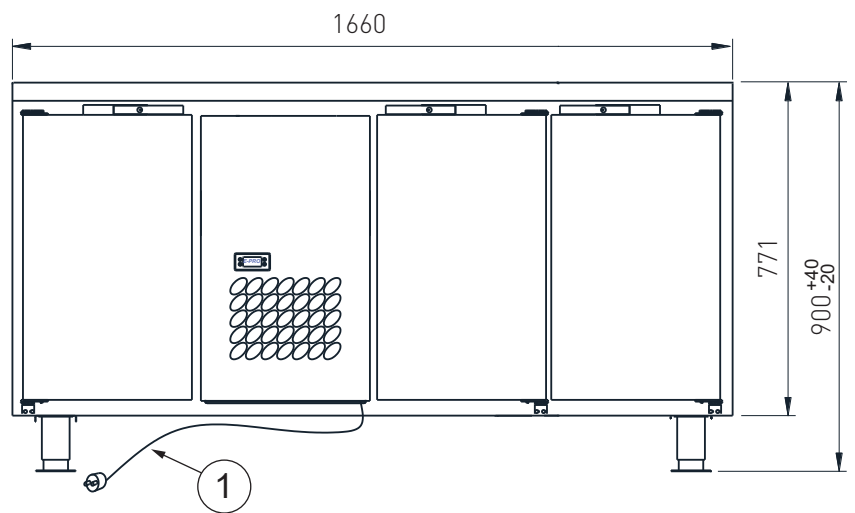

DETAIL MARINE FOOT

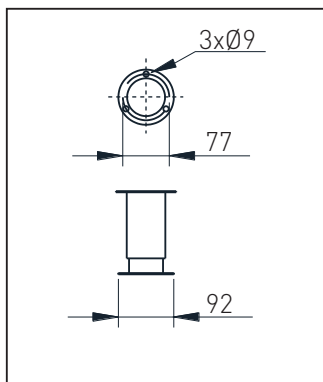

TOP



1. Electrical connection cable 3 m, Schuko plug.