

MULTI STATION HAND WASH SINK



Model : 01-0106

Three Station Hand Wash Sink

Model : 01-0107

Two Station Hand Wash Sink

Model : 01-0108

Three Station Hand Wash Sink With Cabinet

Model : 01-0109

Two Station Hand Wash Sink With Cabinet

- 304 Quality 18/8 CrNi stainless steel sheet material
- Models with legs, base shelves and cabinets
- 4 rutile feet with adjustable height in order to provide balance according to the slope or shape of the floor. (In models with legs and cabinets)
- Lock option in cabinet models

Model: 01-108 General Dimensions:

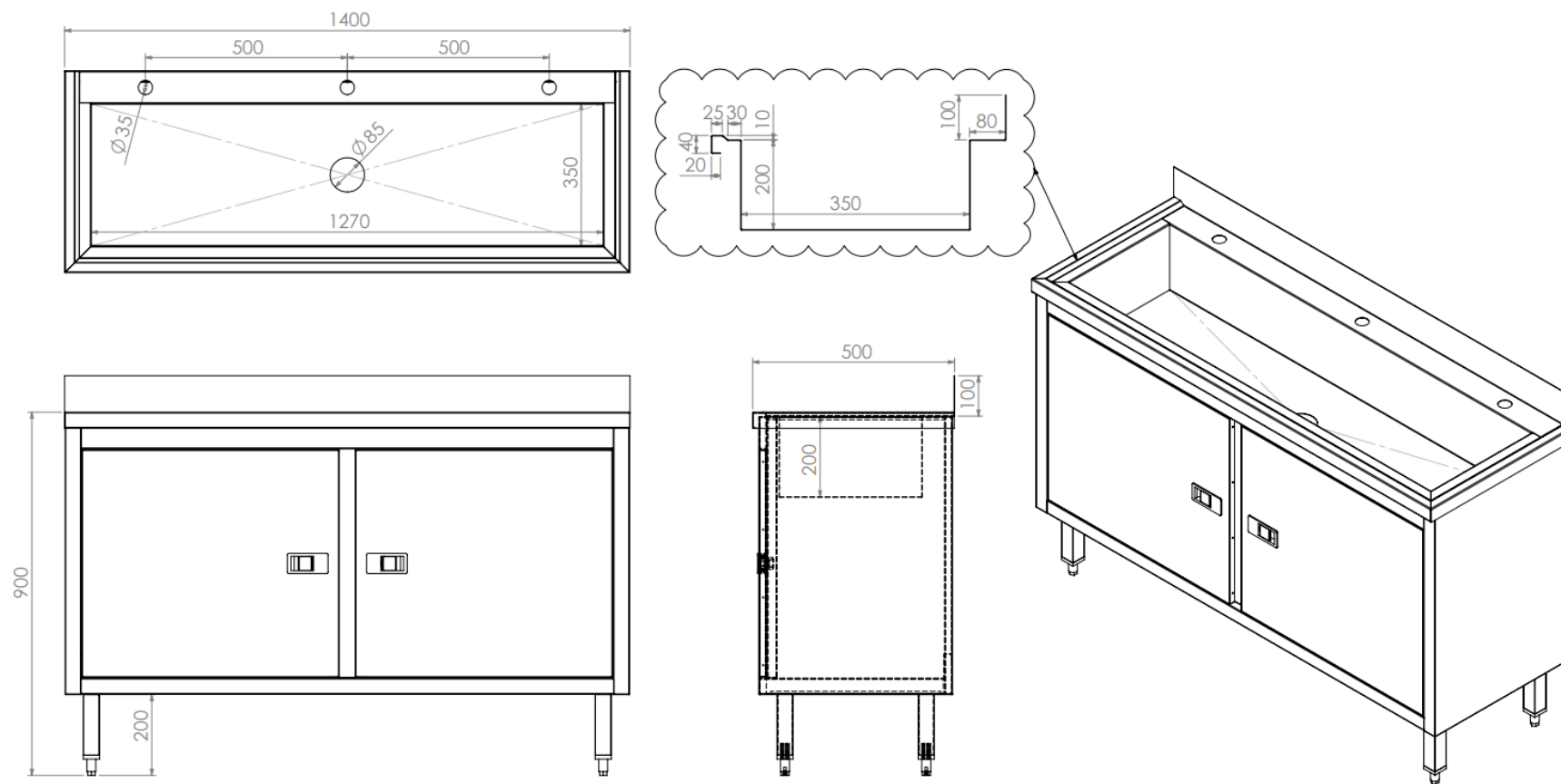

Model: 01-109 General Dimensions:

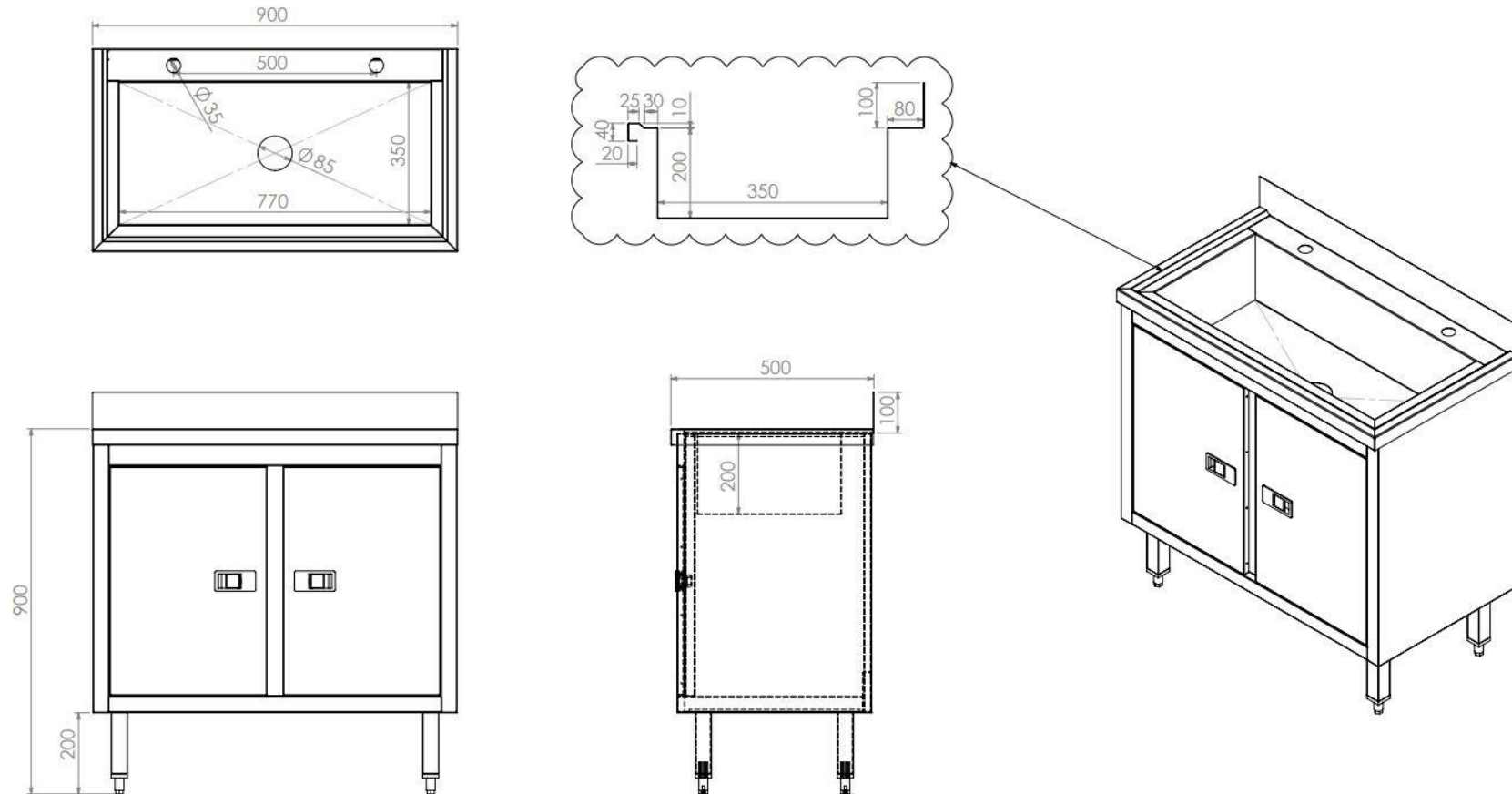

OPTIONS:

1. Rolling Bar Option (1 Set = 1 pc. Mobile front rolling bar + 2 pc. left/right fixed rolling bars)

Please add "Yp" in order

Applicable model: 01-0106 - 01-0107

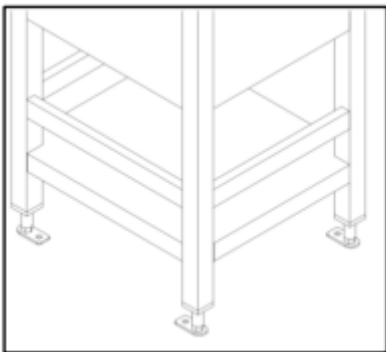

- Right and left side Rolling bars are fixed, front Rolling bar is mobile.

2. Marine feet option (1 set= 4 pcs. of feet)

Please add "Mp" to the code

Applicable model: 01-0106 - 01-0107 - 01-0108 - 01-0109

