



## COMBI OVEN SKYLINE PREMIUM 10 GN 1/1

**Model: ECOE101B2E0**

**Article no: 227812V40035060**

**Power supply: 400V 3Ph ~50-60Hz**

The new SkyLine Combi Ovens are made to deliver outstanding performance with smart technology and human-centred design.

The Premium models have a digital interface with LED backlight buttons and guided selection. A built-in steam generator for highly precise humidity and temperature control and Lambda sensor core probe to automatically recognize the quantity and size of food for consistent quality results. Single sensor core temperature probe included.

Skyline models have a wing-shaped handle with ergonomic design and hands-free opening with the elbow, making managing trays simpler. They have a double thermo-glazed door with open frame construction, for a cool outside door panel. A swing hinged easy-release inner glass on door for easy cleaning. Seamless hygienic internal chamber with all rounded corners for easy cleaning and 304 AISI stainless steel construction.

The oven has an OptiFlow air distribution system to achieve maximum performance in cooking evenness and temperature control thanks to the design of the cooking chamber combined with a venting valve and a high precision variable speed fan. The fan has 5-speed levels from 300 to 1500 RPM and reverse rotation for optimal evenness, and the fan stops in less than 5 seconds when the door is opened. The oven also has automatic fast cool down and pre-heat function and reduced power function for customized slow cooking cycles.

A 1000 recipes can be stored in the oven's memory, to recreate the exact same recipe at any time. The recipes can be grouped into 16 different categories to be easier to find.

### MAIN FEATURES

- Digital interface
- Lambda sensor (humidity control)
- OptiFlow air distribution system
- Boiler in AISI 304
- Fixed tray rack pitch 67mm with tray stopper
- Double-glass door
- Skyclean automatic cleaning
- Human-centred design with 4-star certification for ergonomics and usability

ECOE101B2E0, 227812V40035060

22-01-24 (14:05)

## TECHNICAL DATA

ECOE101B2E0, 227812V40035060, 22-01-24 (14:05)

|  |                                     |
|--|-------------------------------------|
| <b>Model Number Specific</b>             | ECOE101B2E0                         |
| <b>Voltage (V)</b>                       | 400                                 |
| <b>Phase</b>                             | 3                                   |
| <b>Frequency (Hz)</b>                    | 50-60                               |
| <b>Loading (kW)</b>                      | 19                                  |
| <b>Max Amps in Phase (A)</b>             | 28,3                                |
| <b>Fuse (A)</b>                          | 35                                  |
| <b>IP Class</b>                          | X5                                  |
| <b>Capacity, food load max (kg)</b>      | 50                                  |
| <b>Capacity, pans (pcs)</b>              | 10                                  |
| <b>Width, net (mm)</b>                   | 867                                 |
| <b>Depth, net (mm)</b>                   | 775                                 |
| <b>Height, net (mm)</b>                  | 1058                                |
| <b>Weight, net (kg)</b>                  | 145                                 |
| <b>Weight, gross (kg)</b>                | 160                                 |
| <b>Volume, net (m3)</b>                  | 0,71                                |
| <b>Volume, gross (m3)</b>                | 0,92                                |
| <b>Connection Cable, length (m)</b>      | 0                                   |
| <b>Plug type</b>                         | None                                |
| <b>Adapted for container sizes</b>       | GN                                  |
| <b>Automatic cleaning system</b>         | Yes                                 |
| <b>Certifications</b>                    | CE, Ergocert (Ergonomics Certified) |
| <b>Cold water inlet temperature (°C)</b> | max 30                              |
| <b>Cold water inlet, diameter (")</b>    | 3/4                                 |
| <b>Door Hanging</b>                      | Left                                |
| <b>Drain pipe, diameter (mm)</b>         | 50                                  |
| <b>Installation, type</b>                | Table top model, Floor model        |
| <b>Marine feet</b>                       | Yes                                 |
| <b>Noise level &lt;(dB)</b>              | 70                                  |
| <b>Oven, type</b>                        | Combi                               |
| <b>Pan sizes</b>                         | GN1/1                               |
| <b>Temperature, max (°C)</b>             | 300                                 |
| <b>Water pressure, max (Bar)</b>         | 4,5                                 |
| <b>Water pressure, min (Bar)</b>         | 1                                   |

Loipart AB (HQ), Sweden  
Tel. +46 313 920 100, loipart@loipart.se

LMG Finland oy, Finland  
+358 40 664 6680, lmg@lmg.fi



Loipart USA inc, USA  
Tel. +1 954 530 5276, loipartusa@loipart.com

Loipart SEA Pte Ltd, Singapore  
Tel. +65 674 99 100, contact@loipart.sg

Visit us at [www.loipart.com](http://www.loipart.com)

POSITIONING OF MACHINE

|                           |                                    |
|---------------------------|------------------------------------|
| normal working            | right / left / rear distance 50 mm |
| work close to heat source | left side distance 350 to 500 mm   |
| service conditions        | left side distance 500 mm          |

- All appliance sides must remain at 50 mm from any surface.

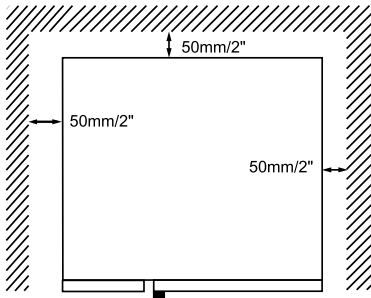

If it's necessary to carry out maintenance works on the appliance, slide it forwards.

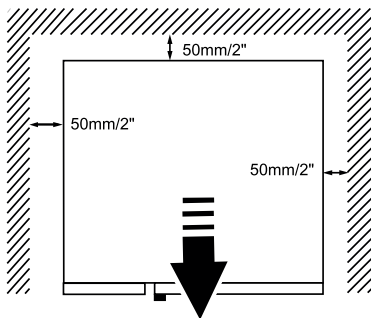

In all models but especially in 20 grids models when possible leave a space of at least 500 mm between the left side of the appliance and the other surfaces to enable maintenance operations.

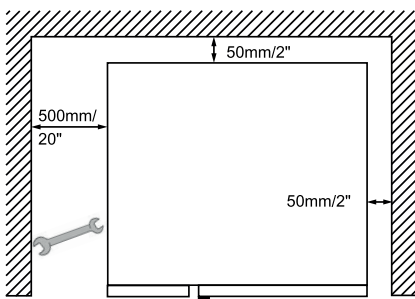

The left gap must be a minimum of 350 mm **if heat sources are acting** on the left side of the appliance.

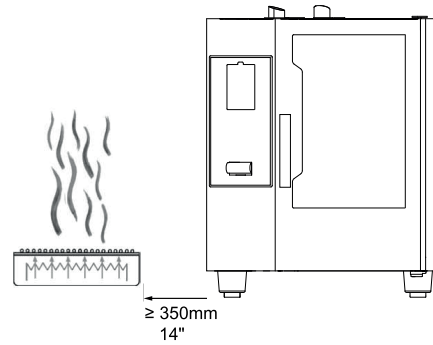

If it is not possible to keep the left side of the appliance a sufficient distance away from heat sources, a heat shield can reduce thermal loads (see accessories catalogue).

If steam from the ventilation pipe cannot be directed into an exhaust hood or a ventilating ceiling, there must be at least 500 mm clearance space above the device.

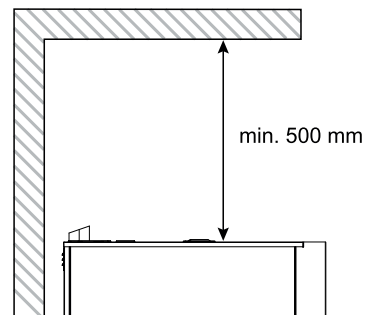

Position the appliance on a flat surface. If necessary, adjust the height of the worktop by means of the adjustable feet (if available).

# DIMENSIONS

Model: ECOE101B2 Rev. 1  
 ECOE101T2  
 ECOE101C2  
 ECOE101K2

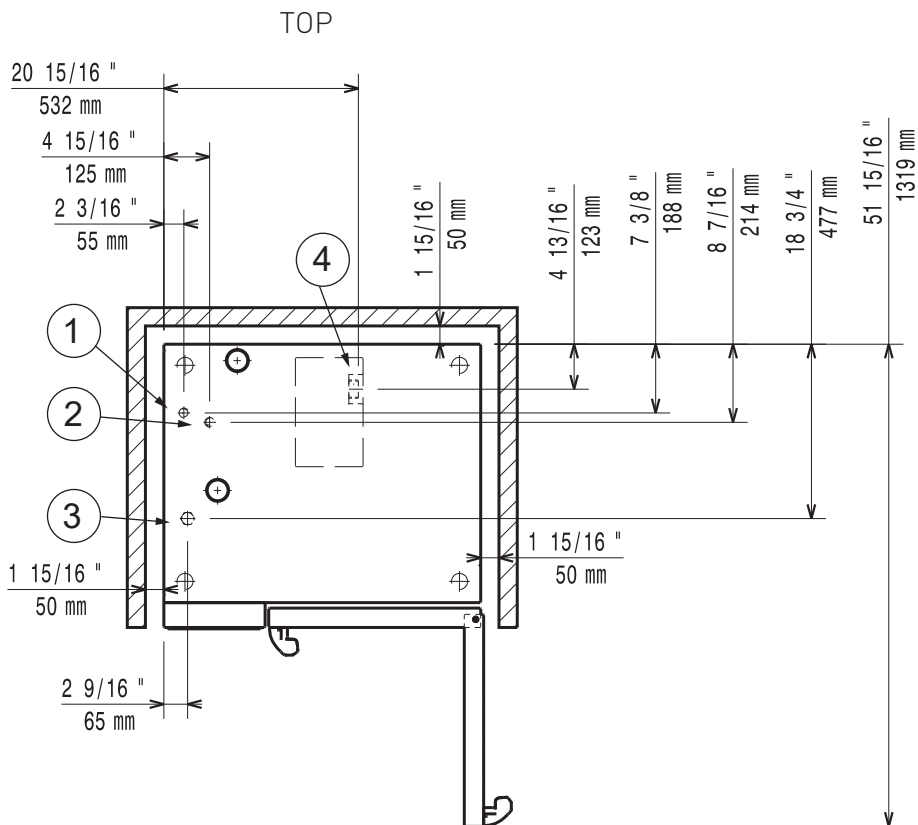
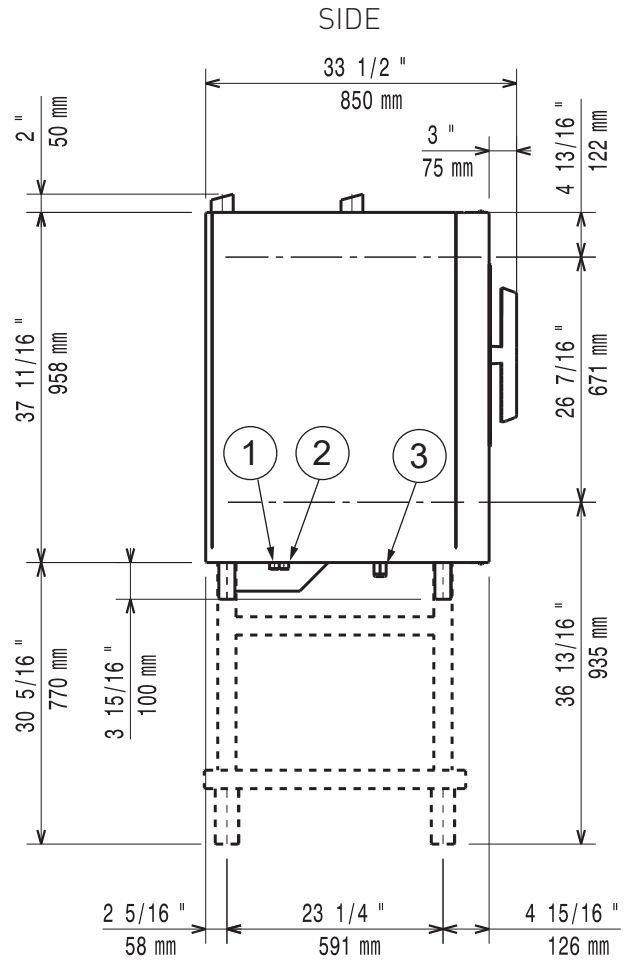
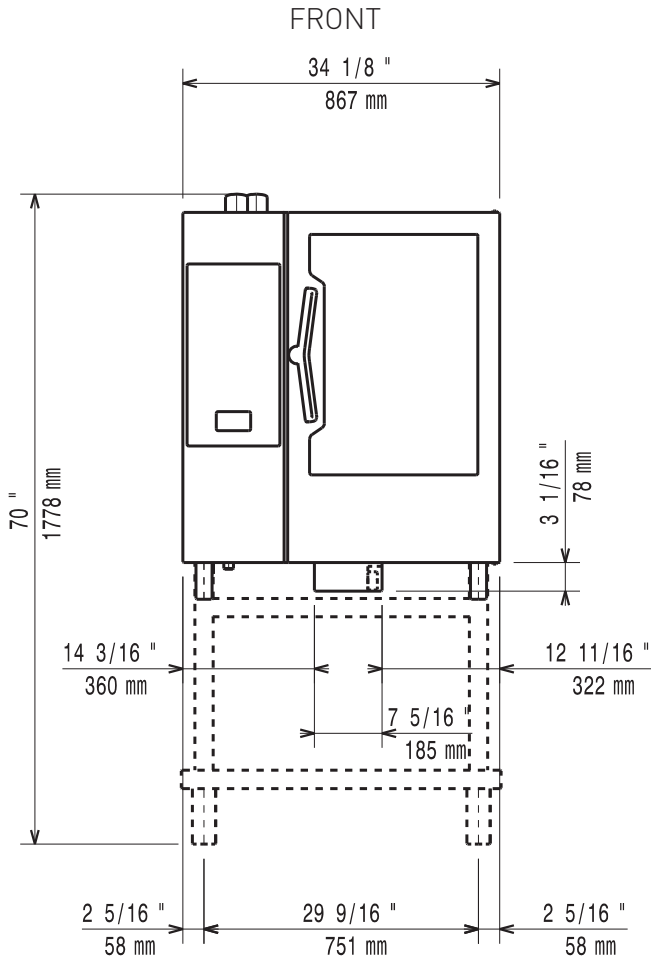

1. Cold water inlet (cleaning system)
2. Cold water inlet (boiler/steam generator)
3. Electrical connection
4. Drain

## DETAIL MARINE FOOT

