



DOUGH SHEETER

Model: STM5304

Article no: L15040

Power supply: 400V 3Ph ~50Hz

The Econom sheeters offer high output in a small package. Whether as a table-top model or base model with marine feet, the Econom sheeter is the ideal machine for galleys, restaurants as well as for small craft bakeries. The Econom sheeters can be used to sheet all dough types with great accuracy. The Econom's modern design makes it almost effortless to use. All operating elements are arranged so as to be within easy reach and able to be operated without physical effort. The Econom is built to last and important components, such as the machine tables are made of stainless steel.

The ergonomic roller adjustment lever enables you to work tirelessly and with the minimum expenditure of effort. The end thickness stop makes easy setting of the desired product thickness. The doughs will always have a consistent end thickness and the products will always be the same size and weight. Econom sheeters use a special, tried and tested scraper system that reliably removes dough and flour residues. The scraper can be quickly removed for cleaning without the need for tools. Thanks to the hygienic design, with smooth surfaces, cleaning takes no time at all. The sheeters have an exceptionally small design and fit in any bakery, no matter how small. After use, simply fold up the working tables and push the sheeter out of the way, leaving your precious space free for other tasks. For further specifications of the different models, please see overleaf.

MAIN FEATURES

- Rigid Construction
- Ergonomic Operation
- With Safety Devices
- Smooth Gliding
- Raisable Working Tables
- Two Table Top or One Floor Models
- Space Saving
- Easy to Maintain
- Hygienic Design
- Easy to Clean

STM5304, L15040

16-01-24 (17:53)

TECHNICAL DATA

STM5304, L15040, 16-01-24 (17:53)

Model Number Specific	STM5304
Voltage (V)	400
Phase	3
Frequency (Hz)	50
Loading (kW)	0,5
Width, net (mm)	2060
Depth, net (mm)	1040
Height, net (mm)	500
Weight, net (kg)	100
Weight, gross (kg)	120
Volume, net (m3)	1
Volume, gross (m3)	1,3
Noise level <(dB)	70

Loipart AB (HQ), **Sweden**
Tel. +46 313 920 100, loipart@loipart.se

LMG Finland oy, **Finland**
+358 40 664 6680, lmg@lmg.fi



Loipart USA inc, **USA**
Tel. +1 954 530 5276, loipartusa@loipart.com

Loipart SEA Pte Ltd, **Singapore**
Tel. +65 674 99 100, contact@loipart.sg

Visit us at www.loipart.com

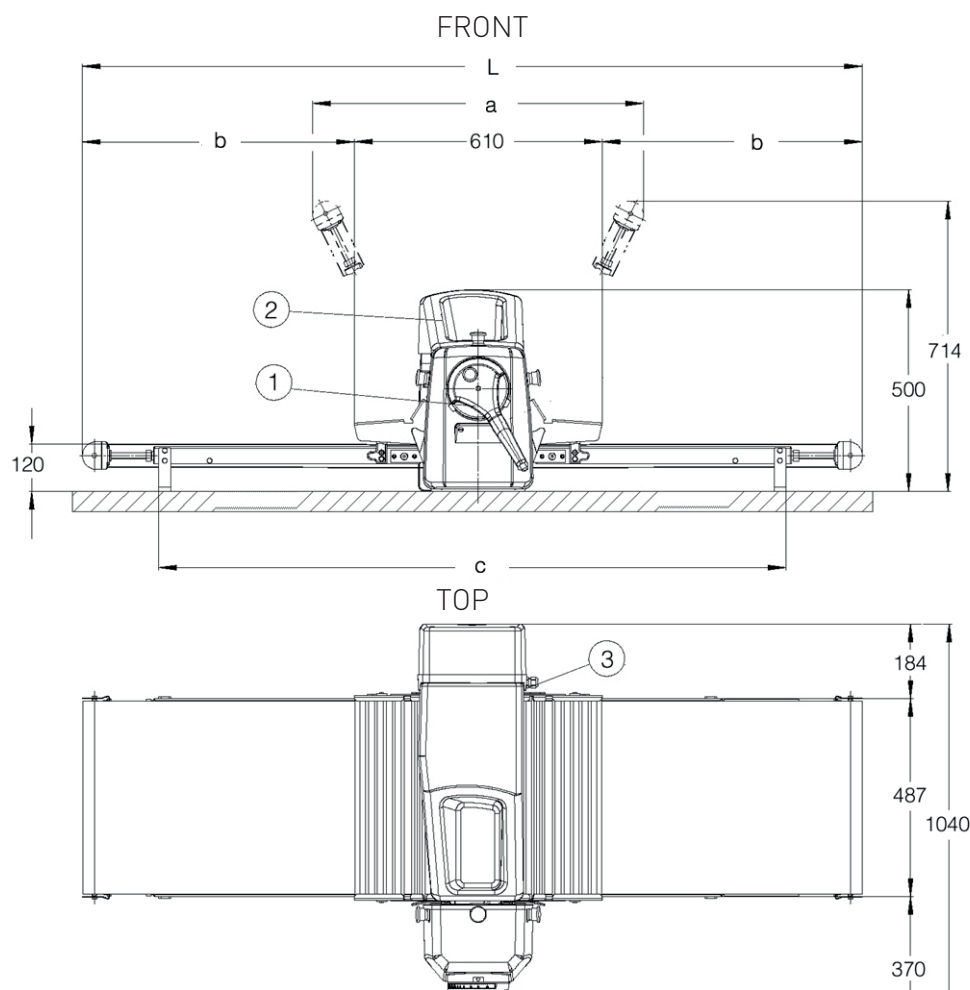

- 1. Roller gap adjustment
- 2. Flour tank
- 3. Electrical connection

Dimensions (mm)

L	a	b	c
max 2060	1040	725	1684