



REFRIGERATOR, 670L, -2+10 C, R290

Model: REX71FRM

Article no: 725226

Power supply: 230V 1Ph ~50Hz

Full door refrigerator with internal and external structure in 304 AISI stainless steel; outer back panel in galvanized steel and bottom panel in anti-corrosive material.

The cabinet has a digital control with temperature display and setting and manual activation of defrost cycle. Fully compliant HACCP digital controls include visible alarms.

The refrigerator has an optimized back-to-front forced airflow that provides even temperature distribution and fast cooling in any condition. It is fitted with 75 mm-thick cyclopentane insulating foam.

The model has a reversible door with a lock and door microswitch to stop the fan when the door is opened. The internal structure offers numerous charging positions available to host grids, ensuring higher net capacity and greater storage space.

MAIN FEATURES

- Operating temperature from -2 to +10 °C
- Digital control with cabinet temperature display
- Setting and manual activation of defrost cycle
- For ambient temperatures up to 43°C
- Large storage area suitable to contain 2/1 GN grids
- Shelves on anti-tilt runners
- Optimised back to front forced air flow
- Even temperature distribution and fast cooling in
- Automatic defrost

REX71FRM, 725226

05-02-24 (13:07)

Subject to change without notice
For correct installation, refer to the installation manual

Model Number Specific	REX71FRM
Voltage (V)	230
Phase	1
Frequency (Hz)	50
Loading (kW)	0,2
Fuse (A)	10
IP Class	21
Width, net (mm)	710
Depth, net (mm)	835
Height, net (mm)	2090
Weight, net (kg)	106
Weight, gross (kg)	116
Volume, net (m3)	1,22
Volume, gross (m3)	1,58
Energy Class	C
Connection Cable, length (m)	3
Plug type	Schuko
Adapted for container sizes	GN
Ambient temperature, max (°C)	43
Automatic defrost	Yes
Basket sizes	GN2/1
Certifications	CE
Condensor type	Air cooled
Cooling capacity (W)	414
Cooling fan	Yes
Door Hanging	Right
Door, type	Stainless steel
Doors, qty (pcs)	1
Exterior	Stainless steel
Filling factor refrigerant (g)	75
Grids, qty (pcs)	3
Installation, type	Floor model
Locking device, included	Yes
Marine feet	Yes

Noise level <(dB)	70
Other general information	Yearly and daily energy consumption: 712kWh/year - 2kWh/24h. Climate class: Heavy Duty (5) Energy Efficiency Index (EEI): 49,58
Refrigerant type	R290
Volume, refrigerator (L)	670

INCLUDED IN DELIVERY

Supplied with 3x2/1GN Rilsan coated grids and three sets of 2 stainless steel grid runners.

Loipart AB (HQ), **Sweden**
Tel. +46 313 920 100, loipart@loipart.se

LMG Finland oy, **Finland**
+358 40 664 6680, lmg@lmg.fi



Loipart USA inc, **USA**
Tel. +1 954 530 5276, loipartusa@loipart.com

Loipart SEA Pte Ltd, **Singapore**
Tel. +65 674 99 100, contact@loipart.sg

Visit us at www.loipart.com

DIMENSIONS

DETAIL OF MARINE FOOT

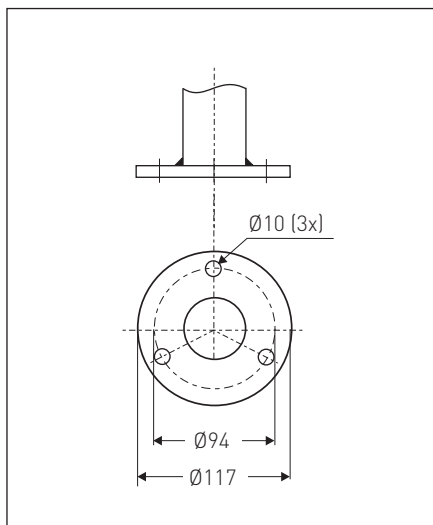

POSITIONING

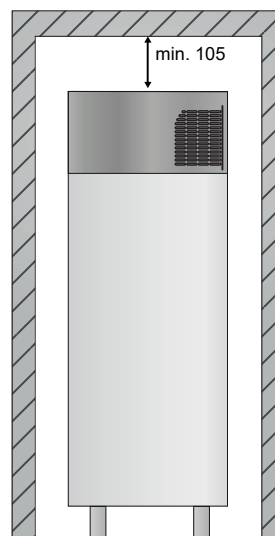
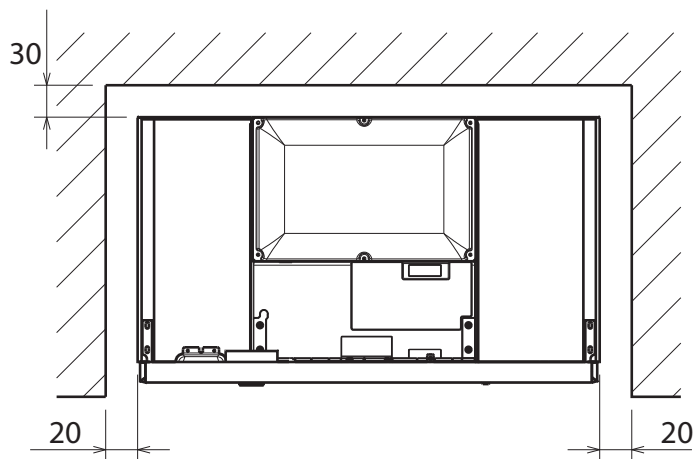

MARINE INSTALLATION

The appliance must be levelled; otherwise its operation could be affected. Adjust the height and level by means of the levelling feet, checking that the door opens and closes properly.

NOTE! For additional instructions of installation please see separate Installation instructions.

DIMENSIONS

Model: REX71FF60MH Rev. 1
 REX71FR60MH
 REX71FRM

FRONT

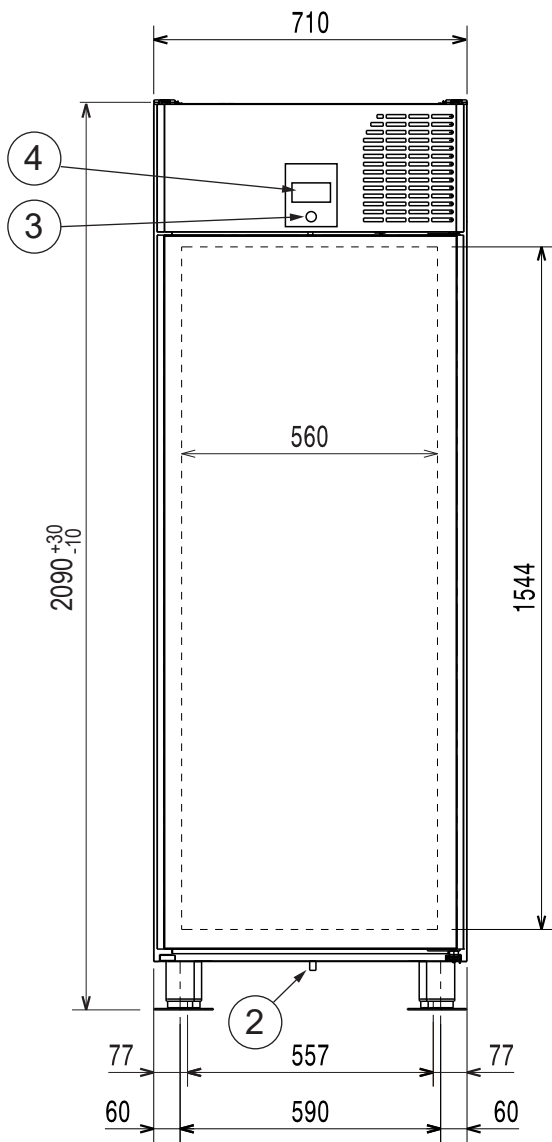

TOP

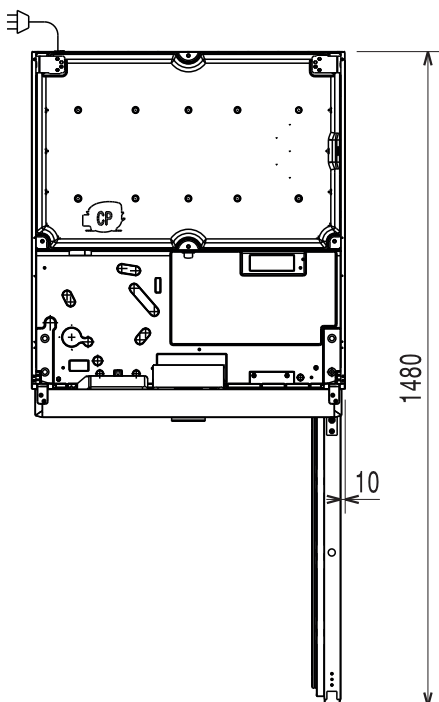

SIDE

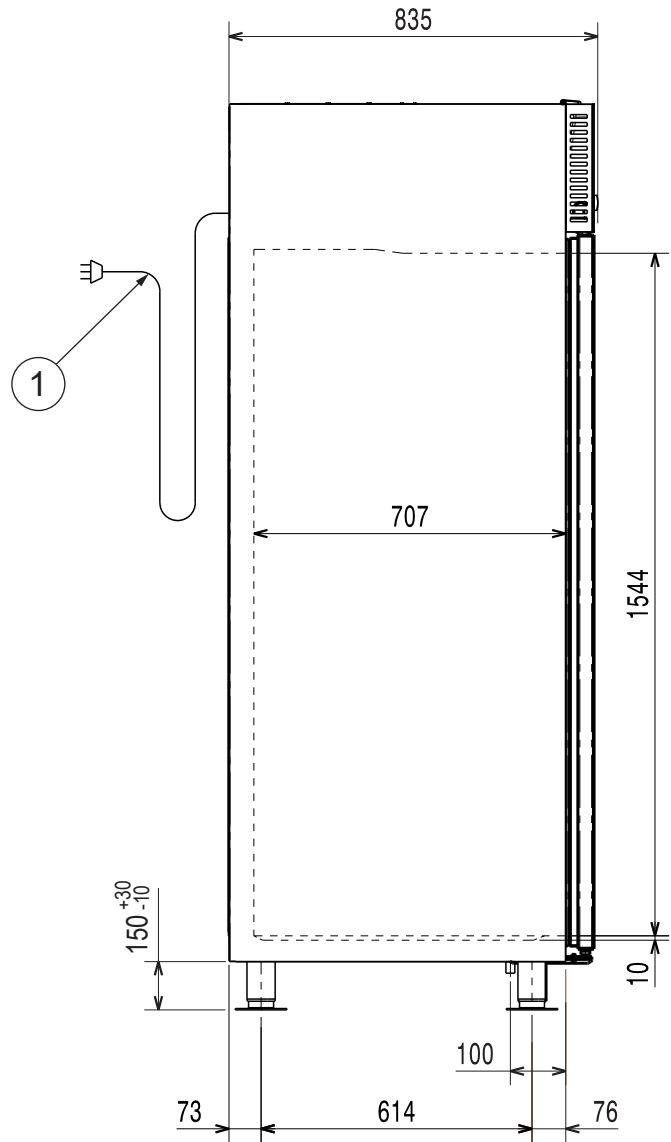

1. Electrical connection, 3 m cord with Schuko plug.
2. Compartment drain hole Ø 17.5 mm.
3. Door lock.
4. Control panel, see manual for more info.